

## Unit 1 – Lab Skills Test – Teacher Edition

### I. Multiple Choice

1. Name the piece of lab equipment to the right:

- a) Beaker
- b) Evaporating basin
- c) Watch glass
- d) Mortar and Pestle

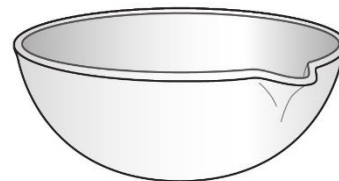

2. Which of the following is an example of a qualitative observation?

- a) The leaves of the plant are drooping.
- b) The inside of the Earth must be liquid.
- c) The water temperature is 23°C.
- d) This toy must have a magnet in it.

3. What is the function of the piece of equipment to the right?

- a) Supports equipment.
- b) Protects the bench.
- c) Spreads heat evenly.
- d) Separates solids and liquids from a mixture.



4. What should you do if break a test tube during an experiment?

- a) Put it in the glass bin immediately.
- b) Put it in the trash
- c) Sweep it to one side to deal with later.
- d) Leave it in the sink.

5. What is the reading on the measuring cylinder?

- a) 6.1ml
- b) 6.2 ml
- c) 6.3 ml
- d) 6.4 ml

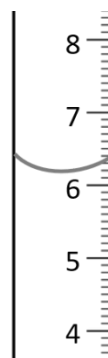

## Unit 1 – Lab Skills Test – Teacher Edition

### II. Convert the following:

1. 42 cm = _____ km	2. 8.7 g = _____ mg	3. 80 mL = _____ L
---------------------	---------------------	--------------------

### III. The Bunsen Burner

1. Label the diagram of the Bunsen burner below.

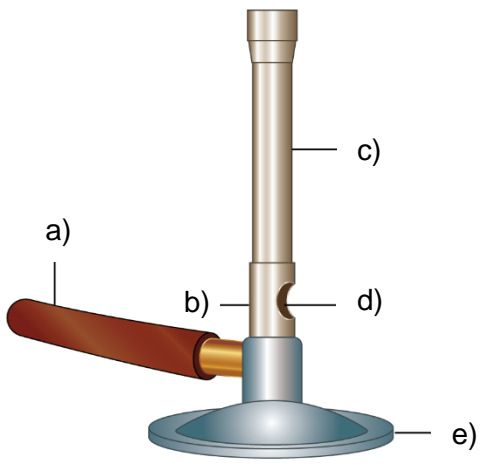
	a)
	b)
	c)
	d)
	e)

2. Describe how to safely light a Bunsen burner.

---

---

---

---

---

3. Describe the function of the collar on the Bunsen.

---

---

---

## Unit 1 – Lab Skills Test – Teacher Edition

### IV. Safety in Science

Read the lab scenarios below. Describe **TWO** safety rules that are not being followed for each scenario.

1. Cindy accidentally broke a test tube. She carefully picks up most of the pieces with her hands and then dumps the sharp, broken pieces in the trash can.

---

---

---

2. Mike and Colleen have a lot of chemicals left after they finished the lab. They are unsure of what to do with them, so they tip them all into the sink and leaving the water running as they go off to their next class.

---

---

---

### V. Investigation Skills

Read the information below and use it to answer the questions.

Clément wants to see if ice melts more quickly on a warm day than on a cooler day. He freezes a tray of ice cubes in his freezer and places 3 cubes in three separate glass containers of the same dimensions. He then times how long it takes for the ice to completely melt over three separate days of different temperatures, (25°C, 20°C, and 15°C) He records the time it takes for the ice to melt, outside temperature and cloud cover for each day in his notebook.

1. Write a hypothesis for Clément's investigation.

---

---

2. What is the independent variable for this investigation?

---

---

Name: \_\_\_\_\_ Period: \_\_\_\_\_ Date: \_\_\_\_\_

## Unit 1 – Lab Skills Test – Teacher Edition

3. Identify the range for the independent variable.

\_\_\_\_\_

4. What is the dependent variable for this investigation?

\_\_\_\_\_

\_\_\_\_\_

5. Draw a graph for Clément's investigation using the data provided below.

Temperature (°C)	Time for 3 ice cubes to melt (mins)
15	90
20	40
25	15



Name: \_\_\_\_\_ Period: \_\_\_\_\_ Date: \_\_\_\_\_

## Unit 1 – Lab Skills Test – Teacher Edition

6. Write a conclusion for this experiment. Using the data above.

---

---

---

### VI. Drawing Equipment

In the space below draw the setup required to evaporate a liquid using a Bunsen and an evaporating basin. Clearly label your diagram.

## Unit 1 – Lab Skills Test – Teacher Edition

### ANSWERS

#### I. Multiple Choice

1. Name the piece of lab equipment to the right:

- a) Beaker
- b) Evaporating basin
- c) Watch glass
- d) Mortar and Pestle

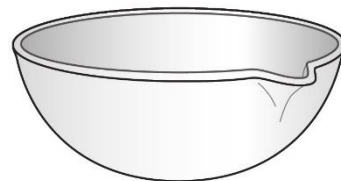

2. Which of the following is an example of a qualitative observation?

- a) The leaves of the plant are drooping.
- b) The inside of the Earth must be liquid.
- c) The water temperature is 23°C.
- d) This toy must have a magnet in it.

3. What is the function of the piece of equipment to the right?

- a) Supports equipment.
- b) Protects the bench.
- c) Spreads heat evenly.
- d) Separates solids and liquids from a mixture.



4. What should you do if break a test tube during an experiment?

- a) Put it in the glass bin immediately.
- b) Put it in the trash
- c) Sweep it to one side to deal with later.
- d) Leave it in the sink.

5. What is the reading on the measuring cylinder?

- a) 6.1ml
- b) 6.2 ml
- c) 6.3 ml
- d) 6.4 ml

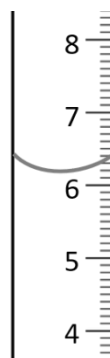

## Unit 1 – Lab Skills Test – Teacher Edition

### II. Convert the following:

1. 42 cm = <b>0.00042</b> km	2. 8.7 g = <b>8700</b> mg	3. 80 mL = <b>0.08</b> L
------------------------------	---------------------------	--------------------------

### III. The Bunsen Burner

1. Label the diagram of the Bunsen burner below.

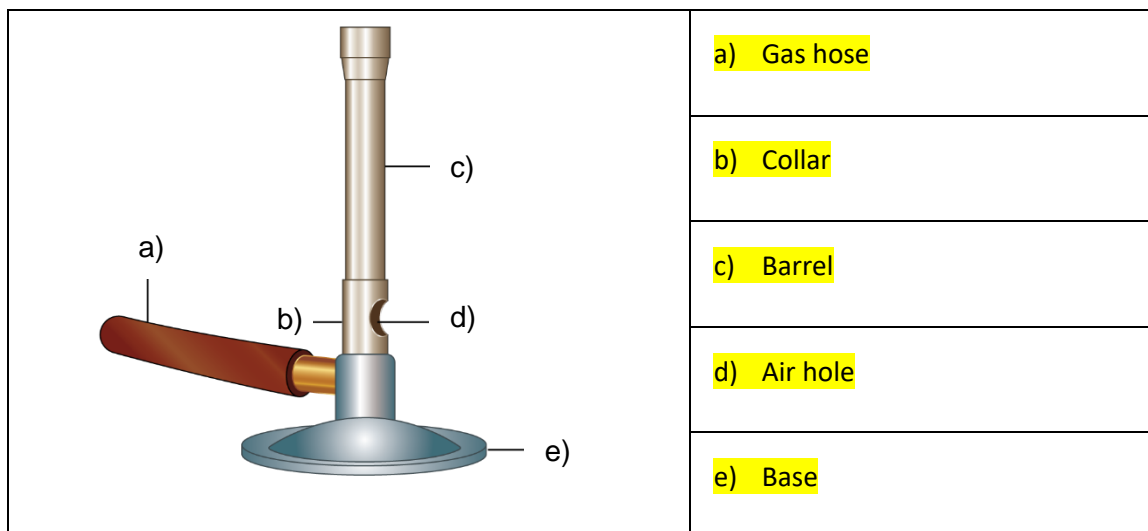

2. Describe how to safely light a Bunsen burner.

- 1) Put on safety glasses.
- 2) Check the hose for damage/barrel for residue.
- 3) Connect the rubber hose to the gas tap.
- 4) Close the airhole by turning the collar.
- 5) Light the match.
- 6) Turn on the gas.
- 7) Hold the match over the top of the barrel.
- 8) Change the flame to blue by turning the collar and opening the air hole

3. Describe the function of the collar on the Bunsen.

**It adjusts the amount of air available to mix with the gas and changes the color (temperature) of the flame.**

## Unit 1 – Lab Skills Test – Teacher Edition

### IV. Safety in Science

Read the lab scenarios below. Describe **TWO** safety rules that are not being followed for each scenario.

1. Cindy accidentally broke a test tube. She carefully picks up most of the pieces with her hands and then dumps the sharp, broken pieces in the trash can.
  - **Never handle broken glass with your bare hands**
  - **Always notify the teacher of any accidents**
  - **Make sure to properly dispose of any broken glass in the glass/sharps bin**
2. Mike and Colleen have a lot of chemicals left after they finished the lab. They are unsure of what to do with them, so they tip them all into the sink and leaving the water running as they go off to their next class.
  - **Check with you teacher for correct disposal of chemicals – not all chemicals can go down the sink.**
  - **Clean and dry glassware after use.**
  - **Make sure to properly clean up your area after any lab work.**

### V. Investigation Skills

Read the information below and use it to answer the questions.

Clément wants to see if ice melts more quickly on a warm day than on a cooler day. He freezes a tray of ice cubes in his freezer and places 3 cubes in three separate glass containers of the same dimensions. He then times how long it takes for the ice to completely melt over three separate days of different temperatures, (25°C, 20°C, and 15°C) He records the time it takes for the ice to melt, outside temperature and cloud cover for each day in his notebook.

1. Write a hypothesis for Clément's investigation.  
**The hotter the day, the faster the ice will melt.**
2. What is the independent variable for this investigation?  
**The outside temperature.**



## Unit 1 – Lab Skills Test – Teacher Edition

3. Identify the range for the independent variable.

**15°C, 20°C, 25°C**

4. What is the dependent variable for this investigation?

**The time taken for the ice to melt**

5. Draw a graph for Clément's investigation using the data provided below.

Temperature (°C)	Time for 3 ice cubes to melt (mins)
15	90
20	40
25	15

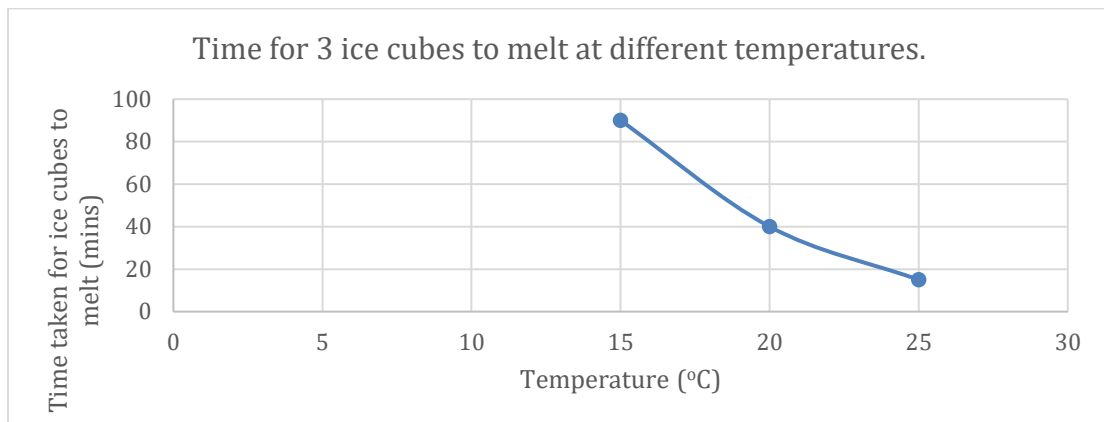

6. Write a conclusion for this experiment. Using the data above.

**The higher the temperature outside, the less time it takes for the ice cubes to melt.**

## Unit 1 – Lab Skills Test – Teacher Edition

### VI. Drawing Equipment

In the space below draw the setup required to evaporate a liquid using a Bunsen and an evaporating basin. Clearly label your diagram.

